

PRODUCT INFORMATION PACKET

Model No: 145THTN8043

Catalog No: Y987

2 HP Variable Speed Motor, 3 phase, 1800 RPM, 230/460 V, 145TC Frame, TENV
2000:1 Brake Motors





Nameplate Specifications

Output HP	2 Hp	Output KW	1.5 kW
Frequency	60 Hz	Voltage	230/460 V
Current	6.0/3.0 A	Speed	1750 rpm
Service Factor	1	Phase	3
Efficiency	85.5 %	Power Factor	78
Duty	Continuous	Insulation Class	F
Design Code	INV	KVA Code	M
Frame	145TC	Enclosure	Totally Enclosed Non Ventilated
Thermal Protection	Thermostats (N/C)	Ambient Temperature	40 °C
Drive End Bearing Size	6205	Opp Drive End Bearing Size	6205
UL	Recognized	CSA	Y
CE	Y	IP Code	43

Technical Specifications

Electrical Type	Squirrel Cage Inverter Duty	Starting Method	Inverter Only
Poles	4	Rotation	Reversible
Resistance Main	6.48 Ohms	Mounting	Rigid Base
Motor Orientation	Horizontal	Drive End Bearing	Ball
Opp Drive End Bearing	Ball	Frame Material	Cast Iron
Shaft Type	T	Overall Length	18.00 in
Frame Length	6.25 in	Shaft Diameter	0.875 in
Shaft Extension	2.12 in	Assembly/Box Mounting	F1/F2 CAPABLE
Outline Drawing	104965-625	Connection Drawing	EE7308T

This is an uncontrolled document once printed or downloaded and is subject to change without notice. Date Created:19/10/2020

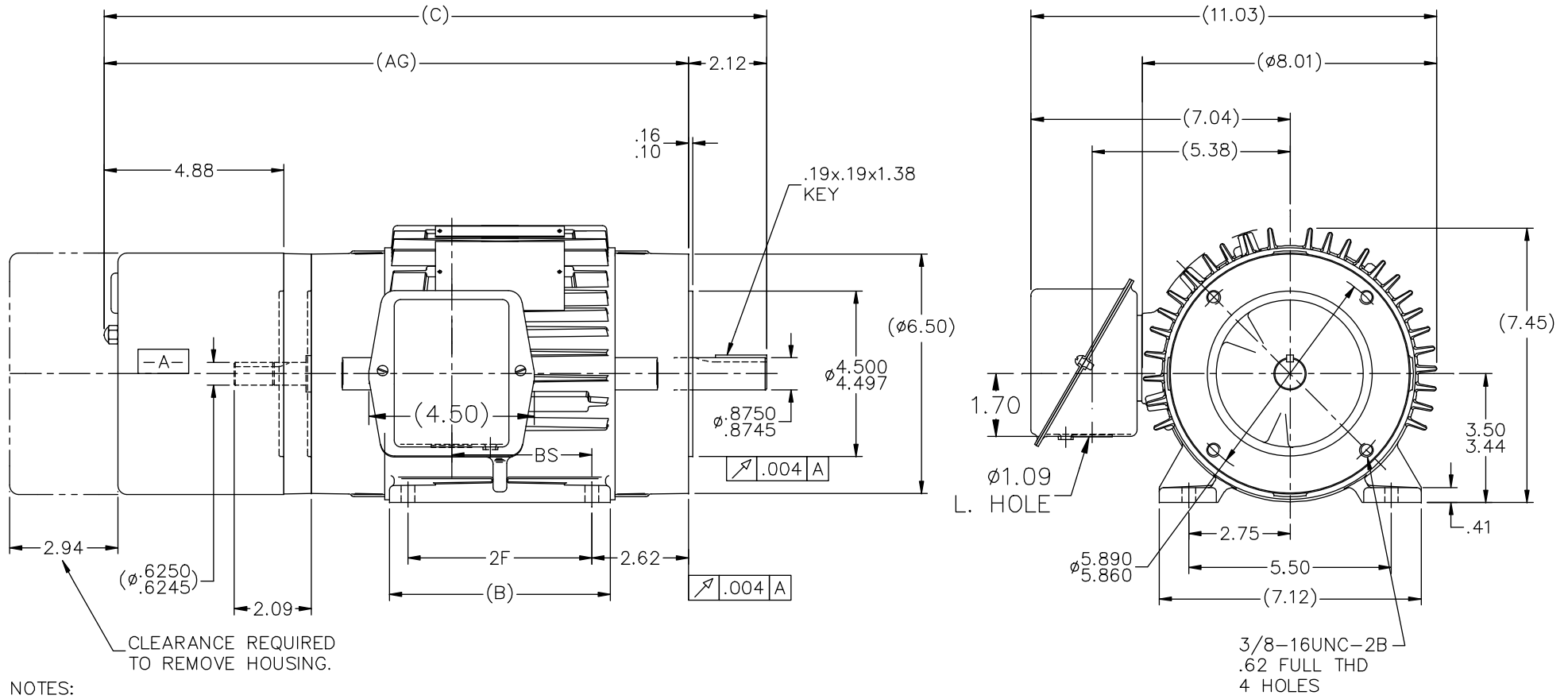

- NOTES:
 1- BOX CAN BE ROTATED IN 90° STEPS.
 2- BOX CAN BE MOUNTED ON OPPOSITE SIDE BY REMOVING BRACKETS AND TURNING FRAME 180°.
 3- NAMEPLATE READ FROM CONDUIT BOX SIDE.

525	143T	17.00	14.88	5.00	4.00	2.81	
625	145T	18.00	15.88	6.00	5.00	3.81	
DASH	FRAME	C	AG	B	2F	BS	

5	CORRECTED COND BOX VIEW PER ECR-0044247	UD 12-10-13	AB	TOLERANCES UNLESS SPECIFIED		DRAWN DRS 05-24-2001	
4	REDRAWN IN AUTOCAD	TAT 06-24-2005	DRS	DEC. INCHES		CHK ML 06-19-2001	
3	REVISED TO SHOW ADAPTER B-92093A, AND REMOVED IF USED NOTE ON 31288	NJS 08-31-2001	.X	±.1	TITLE OUTLINE - C' FACE - TS - TENV 140T FR.-BRAKE & PROVISIONS FOR TACH.	APPD GK 06-19-2001	
2	UPDATED SHAFT EXTENSION ON O.D.E AND ADDED ADAPTER NOTE	DRS 08-17-2001	.XX	±.03		SCALE 3=B	
			.XXX	±.005	MAT'L.	REF	
			.XXXX	±.0005	FINISH	FMF	
NO.	REVISION	BY & DATE	CHK	ANG ±7'30"		PREV	
THIS DRAWING IN DESIGN AND DETAIL IS OUR PROPERTY AND MUST NOT BE USED EXCEPT IN CONNECTION WITH OUR WORK ALL RIGHTS OF DESIGN AND INVENTION ARE RESERVED THIS IS AN ELECTRONICALLY GENERATED DOCUMENT - DO NOT SCALE THIS PRINT					RFP	CAD FILE 104965	SIZE DRAWING NO. PAGE OF REV. B 104965 5
					DIST WP		

HIGH VOLTAGE

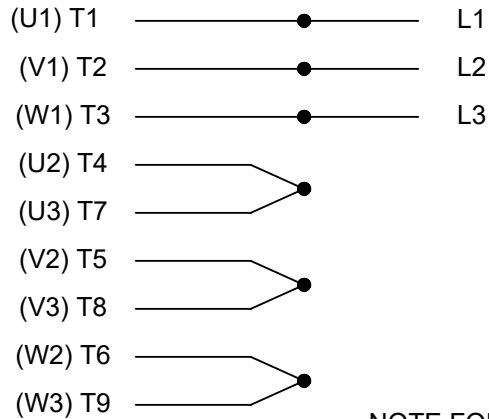

**THREE PHASE
DUAL VOLTAGE MOTOR**

THERMO-PROTECTORS
CONNECTED IN SERIES



NOTE FOR FACTORY USE ONLY:
TO SURGE TEST FOR COMMON CONNECT:
HIGH VOLT: CONNECT P1 TO T1
THEN P2 TO L1
LOW VOLT: CONNECT P1 TO T1 & T7,
THEN P2 TO L1

LOW VOLTAGE

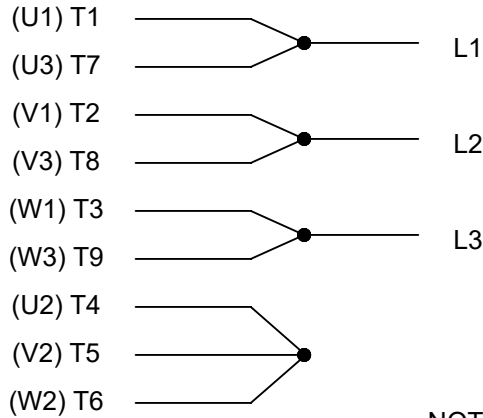

VIEW OF TERMINAL END

NOTE: LEAD'S COLOR CAN BE YELLOW OR WHITE FOR MT2 PLANT

DRAWING REVISION T	REVISION BY ZR	DATE 01-14-2019		DRAWN BY SMC	Regal Beloit America, Inc.
ECO ECO-0159915	APPROVED BY DR	DATE 01-15-2019		DATE 05-13-1992	
ECO DESCRIPTION ADDED TERMINAL CONNECTION DIAGRAM				APPROVED BY TB	DESCRIPTION CONN DIAGRAM-INTERNAL 3 PHASE - DUAL VOLTAGE MOTOR
<small>COPYRIGHT REGAL BELOIT AMERICA, INC. ALL RIGHTS RESERVED. PROPRIETARY AND CONFIDENTIAL INFORMATION - THIS DOCUMENT IS THE PROPERTY OF REGAL BELOIT AMERICA, INC. ("OWNER") AND CONTAINS OWNER'S PROPRIETARY INFORMATION. ANY PERSON, CORPORATION OR OTHER FIRM RECEIVING IT IS DEEMED, BY RECEIVING IT, TO AGREE THAT IT, AND/OR ANY PART OF IT, SHALL NOT BE DISCLOSED TO ANY PERSON, CORPORATION OR OTHER ENTITY, DUPLICATED, AND/OR USED, EXCEPT AS EXPRESSLY APPROVED IN WRITING IN ADVANCE BY OWNER. THIS DOCUMENT SHALL BE RETURNED TO OWNER UPON REQUEST. IT MAY BE SUBJECT TO CERTAIN RESTRICTIONS UNDER APPLICABLE EXPORT CONTROL LAWS AND REGULATIONS.</small>			DATE 05-13-1992	MATERIAL	PROCESS/FINISH
			REFERENCE EE7308/EE7300	SIZE A	DRAWING NUMBER EE7308T
			THIRD ANGLE PROJECTION		

CERTIFICATION DATA SHEET

Model#: 145HTN8043 AA WINDING#: ZT490 F 3
 CONN. DIAGRAM: A-EE7308T ASSEMBLY: F1/F2 CAPABLE
 OUTLINE: A-104965-625

TYPICAL MOTOR PERFORMANCE DATA

HP	KW	SYNC. RPM	F.L. RPM	FRAME	ENCLOSURE	KVA CODE	DESIGN
2	1.49	1800	1750	145TC	TENV	M	INV

PH	Hz	VOLTS	FL AMPS	START TYPE	DUTY	INSL	S.F	AMB°C	ELEVATION
3	60	230/460	6/3	INVERTER ONLY	CONTINUOUS	F3	1.0	40	3300

FULL LOAD EFF: 85.5	3/4 LOAD EFF: 84	1/2 LOAD EFF: 82	GTD. EFF	ELEC. TYPE	NO LOAD AMPS
FULL LOAD PF: 78	3/4 LOAD PF: 66	1/2 LOAD PF: 53.5	82.5	SQ CAGE INV DUTY	3.4 / 1.7

F.L. TORQUE	LOCKED ROTOR AMPS	L.R. TORQUE	B.D. TORQUE	F.L. RISE°C
6 LB-FT	50 / 25	21.8 LB-FT 363	28.5 LB-FT 475	85

SOUND PRESSURE @ 3 FT.	SOUND POWER	ROTOR WK^2	MAX. WK^2	SAFE STALL TIME	STARTS /HOUR	APPROX. MOTOR WGT
62 dBA	72 dBA	0.13 LB-FT^2	0 LB-FT^2	0 SEC.	0	83 LBS.

EQUIVALENT WYE CKT.PARAMETERS (OHMS PER PHASE)

R1	R2	X1	X2	XM
3.834	2.8968	5.9498	5.6374	154.78

RM	ZREF	XR	TD	TD0
6560.4	142	1.6	0.0061	0.147

*** SUPPLEMENTAL INFORMATION ***

DE BRACKET TYPE	ODE BRACKET TYPE	MOUNT TYPE	ORIENTATION	SEVERE DUTY	HAZARDOUS LOCATION	DRIP COVER	SCREENS	PAINT
C-FACE	BRAKE AND ENCODER	RIGID	HORIZONTAL	FALSE	NONE	FALSE	NONE	BLUE (POWDER)

BEARINGS		GREASE	SHAFT TYPE	SPECIAL DE	SPECIAL ODE	SHAFT MATERIAL	FRAME MATERIAL
DE	OPE	POLYREX EM	T	NONE	NONE	1144 STRESSPROOF (C-223)	CAST IRON
BALL	BALL						
6205	6205						

THERMO-PROTECTORS				THERMISTORS	CONTROL	SPACE /n HEATERS
THERMOSTATS	PROTECTORS	WDG RTDs	BRG RTDs			
TSTATS (N/C)	NOT	NONE	NONE	NONE	FALSE	NONE VOLTS

If Inverter equals NONE, contact factory for further information

*
N
O
T
E
S
*

INVERTER TORQUE: CONSTANT 2000:1
INV. HP SPEED RANGE: 2.0 X BASE SPEED
ENCODER: PROVISIONS ONLY
NONE NONE
NONE NONE PPR
BRAKE: REGAL SUPPLIED AND MOUNT

NONE	
STEARNS	P/N 91697-10A1KB
56,000	NEMA 2
10 FT-LB	208-230/460-190/380 V
60/50 Hz	

DATE: 06/23/2017 02:00:24 AM
FORM 3531 REV.3 02/07/99
** Subject to change without notice.

Data Sheet

Date: 19-06-2017
 Customer: _____
 Attention: _____
 Submitted by: FAREEDA DUDEKULA



145THTN8043

Submittal

Data @ 460 V

Motor Load Data

Load	0%	25%	50%	75%	100%	115%	125%	LR
Current (Amps)	1.70	1.90	2.10	2.50	3.0	3.3	3.5	25.0
Torque (ft-lb)	0.00	1.50	3.0	4.5	6.0	6.8	7.5	21.8
RPM	1800	1788	1776	1765	1750	1,746	1740	0
Efficiency (%)		73.5	82.0	84.0	85.5	85.3	85.0	
P.F. (%)	7.8	34.5	53.5	66.0	78.0	79.5	81.0	65.0

Motor Speed Data

	LR	Pull-Up	BD	Rated	Idle
Speed (RPM)	0	900	1500	1750	1800
Current (Amps)	25.0	22.5	18.5	3.0	1.70
Torque (ft-lb)	21.8	19.5	28.5	6.0	0.00

Information Block

HP	2.0			
Sync. RPM	1800			
Frame	145			
Enclosure	TENV			
Construction	TTN			
Voltage	230/460 V			
Frequency	60 Hz			
Design	B			
LR Code letter	M			
Service Factor	1.0			
Temp Rise @ FL	90 ° C			
Duty	CONT			
Ambient	40 ° C			
Elevation	1,000 feet			
Rotor/Shaft wk ²	0.13 Lb-Ft ²			
Ref Wdg	ZT490 F			
Sound Pressure @ 1M	62 dBA			
VFD Rating	CONSTANT 2000:1			
Outline Dwg	A-104965-625			
Conn. Diag	A-EE7308T			
Additional Specifications:				
0				
365THFS8036				
EQUIV CKT (OHMS / PHASE)				
R1	R2	X1	X2	Xm
3.8340	2.8970	5.9500	5.6370	154.7800

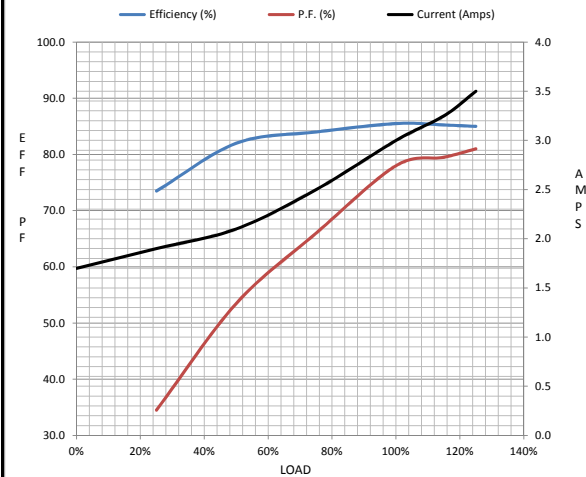

Speed -Torque Curve

